



Paper Type: Original Article

A Novel Ranking Model Based on Perceptual Computer (Per-C) for Selecting Sustainable Projects

Ali Khalilo^{1*} , Seyed Esmacil Najafi¹ , Reza Rasinojehdehi¹ 

¹ Department of Industrial Engineering, Science and Research Branch, Islamic Azad University, Tehran, Iran; ali.khalilo@gmail.com; najafi1515@yahoo.com.; reza.rasi1515@gmail.com.

Citation:

Received: 19 June 2024

Revised: 05 August 2024

Accepted: 09 September 2024

Khalilo, A., Najafi, S. E., & Rasinojehdehi, R. (2024). A novel ranking model based on perceptual computer (Per-C) for selecting sustainable projects. *Risk assessment and management decisions*, 1(1), 119-141.

Abstract

Six Sigma is a comprehensive quantitative improvement method that can achieve impressive results. The project-based approach eliminates waste, reduces costs, increases profits, and improves organization quality. Project evaluation and selection are initial activities in implementing Six Sigma and are crucial in organizations. There are many studies available to help decision-makers handle the process of project selection, but in many decision-making problems, they have to make decisions with incomplete information and under uncertain situations. On the other hand, regarding the development of new concepts, such as sustainability and its role in achieving key outcomes, we used the concepts of the Perceptual Computer (Per-C) method. We proposed a model that incorporates the sustainability concept into project selection. In this model, we designed a Rule-based Computing With Words (CWW) engine according to the three stages of the Per-C method, the outputs of which are in the form of a recommendation. Finally, we used a real-world case to demonstrate the proposed model.

Keywords: Ranking projects, Perceptual computer, Sustainability, Computing with words, Rule-based CWW engine.

1 | Introduction

Today, the increasing competitiveness of enterprises depends on how much the price and quality of products or services, after-sales service, and ultimately, profit margins for stakeholders are satisfactory. Proper and effective selection and approval approaches are the main factors affecting Six Sigma, a comprehensive quantitative improvement method for achieving impressive results [1]. The project-based approach eliminates waste, reduces costs, increases profits, and improves the organization's quality, achievable through the project-based approach [2]. DMAIC is a widely applicable tool used to drive Six Sigma projects. In other words,

 Corresponding Author: ali.khalilo@gmail.com

 <https://doi.org/10.48314/ramd.v1i1.46>



Licensee System Analytics. This article is an open access article distributed under the terms and conditions of the Creative Commons Attribution (CC BY) license (<http://creativecommons.org/licenses/by/4.0>).

DMAIC is a systematic and orderly method for problem-solving and driving such projects. DMAIC is an acronym for the five phases that make up the process [3]:

- I. Define the problem, improvement activity, opportunity for improvement, project goals, and customer (internal and external) requirements.
- II. Measure process performance.
- III. Analyze the process to determine root causes of variation, poor performance (defects).
- IV. Improve process performance by addressing and eliminating the root causes.
- V. Control the improved process and future process performance.

The prioritization and selection of Six Sigma improvement projects, performed in the "Define" phase, are the most challenging and controversial activities in Six Sigma projects. Proper project selection can improve the potential advantages of Six Sigma. In addition, any mistakes in the selection process lead to the failure of Six Sigma projects. There are various methods for evaluating and selecting projects, some of which are presented in *Table 1*.

Table 1. Project selection methods and example.

Category	Approach	Researcher/s
Multiple Criteria Decision Making (MCDM)	Analytic Hierarchy Process (AHP)	Yang and Hsieh [4]
	AHP	Laosirihongthong et al. [5]
	Analytic Network Process (ANP)	Saghaei and Didehkhan [6]
Hybrid Approach	QFD and AHP	Zellner et al. [7]
	Fuzzy AHP and fuzzy goal programming	Mansoori et al. [8]
	Fuzzy MCDM & Delphi	Shaygan and Testik [9]
Mathematical Programming	Linear programming	Padhy and Sahu [10]
	Quadratic programming	Kalashnikov et al. [11]
	Multi-objective programming	Sitek and Wikarek [12]
Artificial Intelligence	Adaptive neuro-fuzzy inference system	Bermudez Peña et al. [13]
Other methods	Brainstorming, interviewing, QFD, Kano model, groups	Khan et al. [14]
	Focus	
	Matrix ranking of project	Tansakul and Yenradee [15]
	QFD	Abyaneh and Nojehdehi [16]

Using these methods, especially MCDM, for evaluating and selecting projects, decision-makers face challenges [17], [18]. One of these challenges is that in many decision problems, decision-makers typically prefer to assess alternatives in linguistic terms instead of numerical forms and tend to form the output of these problems as words. Still, the output of these methods is pure numbers. It leads to the missing subjectivity of decision-makers' assessments. On the other hand, in new approaches such as Fuzzy Inference System (FIS) or Neural Networks, since the core of the methods is an IF-Then Rule-based system, there is a challenge that all rules that each decision-maker constructs for selecting projects will not be chosen. In some cases, rules are specified, or decision-makers reach a consensus on only a few rules.

We propose a novel ranking model based on the Per-C method to address the challenges. Per-C has three components: Encoder, Computing With Words (CWW) engine, and Decoder. Using Perceptual Reasoning (PR) in the CWW engine takes all rules, and none are attended. We present the outputs of the Per-C for selecting projects linguistically in the form of a recommendation by using Jaccard's similarity measure in the Decoder.

Nowadays, sustainable development is a new paradigm that has received a lot of attention in many areas. In project selection problems, some researchers have considered only the concept of selection criteria in their process. Still, in this paper, in addition to the idea of sustainability, the concept is considered for determining criteria and used for designing the proposed model [19]–[22].

The rest of this paper is organized as follows: Section 2 provides an overview of the Interval Type 2 Fuzzy Sets (IT2FSs) theory. In Section 3, the theoretical background of Perceptual Computer (Per-C). In Section 4, the details of the proposed model are presented. In Section 5, we provide a case study to illustrate the effectiveness and applicability of the proposed approach. Finally, conclusions are drawn in Section 6.

2 | Interval Type 2 Fuzzy Sets

This section briefly reviews the basic concepts of Type-2 Fuzzy Sets (T2 FS) and Interval Type-2 Sets (IT2 FS).

A T2 FS in the universal of discourse X by a type-2 membership function $\mu_{\tilde{A}}(x, u)$, is shown as follows [23]:

$$\tilde{A} = \{(x, u), \mu_{\tilde{A}}(x, u) \mid \text{for all } x \in X, \text{ for all } u \in J_x \subseteq [0, 1]\}. \quad (1)$$

In which $0 \leq \mu_{\tilde{A}}(x, u) \leq 1$.

Where x is the primary variable, $J_x \in [0, 1]$ is the primary membership of x , u is the secondary variable, and $\mu_{\tilde{A}}(x, u)$ is the secondary membership function at x . A T2 FS, denoted as \tilde{A} , can be characterized as [23]:

$$\tilde{A} = \int_{x \in X} \int_{u \in J_x} \frac{\mu_{\tilde{A}}(x, u)}{(x, u)}, \quad (2)$$

where $J_x \subset [0, 1]$ and \int denotes union over all admissible x and u . For discrete universes of discourse \int is replaced by \sum [23].

In a general T2 FS, when all $\mu_{\tilde{A}}(x, u) = 1$, then \tilde{A} is an IT2 FS. Although the third dimension (i.e., $\mu_{\tilde{A}}(x, u)$) of the IT2 FSs is no longer needed because it conveys no new information about the IT2 FSs (i.e., $\mu_{\tilde{A}}(x, u) = 1$ for all x and u), the IT2 FSs can still be expressed as a special case of the general T2 FSs as follows [23]:

$$\tilde{A} = \int_{x \in X} \int_{u \in J_x} \frac{1}{(x, u)} \quad J_x \subseteq [0, 1]. \quad (3)$$

Uncertainty in the primary memberships of a general T2 FS, $\tilde{A} = \int_{x \in X} \int_{u \in J_x} \mu_{\tilde{A}}(x, u) / (x, u)$, consists of a bounded region that we call the Footprint Of Uncertainty (FOU). It is the union of all primary memberships, i.e., [24]:

$$\text{FOU}(\tilde{A}) = \bigcup_{x \in X} J_x. \quad (4)$$

$$\tilde{A} = \frac{1}{\text{FOU}(\tilde{A})}. \quad (5)$$

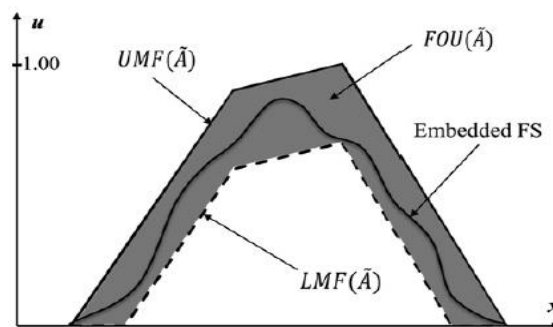

Fig. 1. UMF (Solid), LMF (dashed), FOU (Shaded) and an embedded T1 FS (wavy line) for IT2 FS \tilde{A} [24].

Observe also that an IT2 FS is bounded from above and below by two T1 FSs, which are called Upper Membership Function (UMF) and lower membership function (LMF), respectively (Fig. 1). The UMF and lower MF of the T2FS \tilde{A} are T1 MFs. That bounded its FOU. An embedded T1 FS2 is any T1 FS within the

FOU. The UMF denoted $\bar{\mu}_{\tilde{A}}(x)$, for all $x \in X$ and the LMF denoted $\underline{\mu}_{\tilde{A}}(x)$, for all $x \in X$ are type-1 membership functions, respectively [23].

$$\text{FOU}(\tilde{A}) = \bigcup_{x \in X} [\underline{\mu}_{\tilde{A}}(x), \bar{\mu}_{\tilde{A}}(x)]. \quad (6)$$

3 | Perceptual Computer

The Per-C is an instantiation of Zadeh's CWW paradigm, as applied to assist people in making subjective judgments (*Fig. 2*). The Per-C consists of three components: an Encoder, which maps words into IT2FS models activating a CWW engine. It contains an application's codebook, a collection of words (the application's vocabulary), and IT2 FS models. How to obtain IT2 FS models for words is explained in [25]. The Per-C also consists of a CWW engine, which operates on the input words and whose outputs are Foot of Uncertainty (FOU(s)); a Decoder, which maps these FOU(s) into a recommendation. The output of the CWW engine is mapped into a word (in the vocabulary) most similar to it.

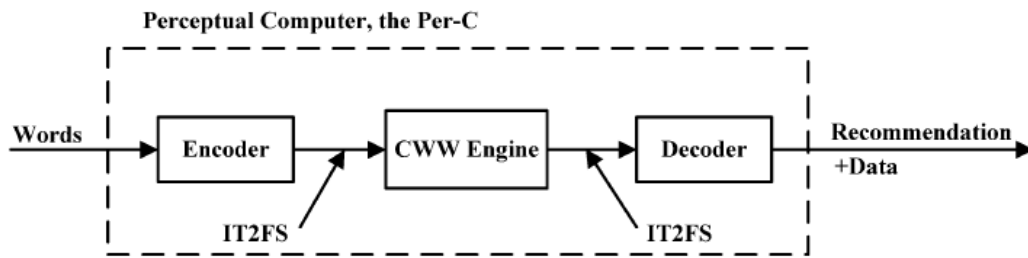

Fig. 2. Per-C [26].

There are many methods to construct if-then rules from data [27], [28] or people [29]. The use of if-then rules in a CWW engine is quite different from their use in most engineering applications of rule-based systems (Fuzzy Logic Systems (FLSs)) because the output of the Per-C is a recommendation, but in an FLS, the output is almost always a number.

The following sections, describe the Per-C components for creating a rule-based CWW engine.

3.1 | Encoder

To construct a rule-based CWW engine, one must first ask: "What kinds of IT2 FSs should be used to model antecedent, consequent, and input words in a rule-based CWW engine?" Mendel et al. [30] proposed the Interval Approach (IA) method for encoding. Later, Wu et al. [24] proposed the Enhanced Interval Approach (EIA) for encoding. The EIA method is based on collecting interval endpoint data from a group of subjects and does not require subjects to be knowledgeable about fuzzy sets; hence, it can be used by anyone. The EIA consists of the data part and the Fuzzy Set (FS) part. For encoding based on this approach, at first, for each word in an application Encoding vocabulary, a group of subjects is asked the following question:

On a scale of 0-10, what are the endpoints of an interval that you associate with the word ...?

After some preprocessing, during which some intervals (e.g., outliers) are eliminated, each of the remaining intervals is classified as an interior, left-shoulder, or right-shoulder IT2 FS. Then, each word's data interval is individually mapped into its respective T1 interior, left-shoulder, or right-shoulder MF, after which the union of all these T1 MFs is taken. The result is a FOU for an IT2 FS model of the word (*Fig. 3*). The words and their FOU's constitute a codebook [31]. The output of this step is used in the CWW engine and Decoder. Details of the EIA method can be found in [24].

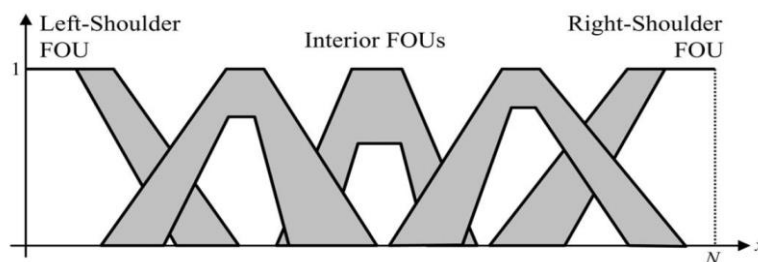

Fig. 3. FOUs for CWWs [26].

3.2 | CWW Engine and Decoder

In this paper, the CWW engine maps IT2 FSs into IT2 FSs employing PR, which combines all fired rules using a novel Linguistic Weighted Average (LWA).

3.2.1 | Perceptual reasoning

Let \tilde{X}' denote an $N \times 1$ vector of IT2 FSs that are the inputs to a collection of N rules, as would be the case when such inputs are words. $F^i(\tilde{X}')$ denotes a firing level for the i th rule, computed only for the $n \leq N$ number of fired rules, i.e., the rules whose firing level does not equal zero.

In PR, the fired rules are combined using a LWA. Denote the output IT2 FS of PR as \tilde{Y}_{PR} . For more details on how the LWA is computed, see [32].

It can be written in the following expressive way:

$$\tilde{Y}_{PR} = \frac{\sum_{i=1}^n F^i(\tilde{X}') \times \tilde{G}_i}{\sum_{i=1}^n F^i(\tilde{X}')}, \quad (7)$$

where \tilde{G}_i and $F^i(\tilde{X}')$ are IT2 FSs.

PR has two steps [32]:

- I. A firing quantity is computed for each rule, and there are two kinds of firing quantities: firing interval and firing level.
- II. The IT2 FS consequents of the fired rules are combined using a LWA [33] in which the weights are the Firing Levels and the signals are the IT2 FS consequents.

PR using firing level is better than PR firing intervals, and it is simple to compute, so we used PR using firing levels in this paper.

How to compute \tilde{Y}_{PR} is explained in the following for firing levels.

PR using firing level

Let the p inputs that activate a collection of N rules be denoted by \tilde{X}' . The result of the input and antecedent operations for the i th fired rule is the firing level $F^i(\tilde{X}')$, where

$$F^i(\tilde{X}') = \min_{s_j}(\tilde{X}'_1, \tilde{F}_1^i), \dots, \min_{s_j}(\tilde{X}'_p, \tilde{F}_p^i) \equiv f^i, \quad j = 1, \dots, p, \quad i = 1, \dots, N. \quad (8)$$

In which $s_j(\tilde{X}'_j, \tilde{F}_j^i)$ is the Jaccard's similarity measure for IT2 FSs [32],

$$s_j(\tilde{X}'_j, \tilde{F}_j^i) = \frac{\int_{\underline{X}} \min(\bar{X}_j(x), \bar{F}_j^i(x)) dx + \int_{\underline{X}} \min(\underline{X}_j(x), \underline{F}_j^i(x)) dx}{\int_{\underline{X}} \max(\bar{X}_j(x), \bar{F}_j^i(x)) dx + \int_{\underline{X}} \max(\underline{X}_j(x), \underline{F}_j^i(x)) dx}. \quad (9)$$

Computing \tilde{Y}_{PR}

An interior FOU for rule consequent \tilde{G}^i is depicted in *Fig. 4(a)*. Observe that for an interior FOU, the height of \tilde{G}^i is denoted $h_{\tilde{G}^i}$, the α -cut on \tilde{G}^i is denoted $[a_{ir}(\alpha), b_{il}(\alpha)]$, $\alpha \in [0, h_{\tilde{G}^i}]$, and the α -cut on \underline{G}^i is denoted $[a_{il}(\alpha), b_{ir}(\alpha)]$, $\alpha \in [0, 1]$. For the left shoulder \tilde{G}_i depicted in *Fig. 4(b)*, $h_{\tilde{G}^i}=1$ and $a_{il}(\alpha) = a_{ir}(\alpha) = 0$ for for all $\alpha \in [0,1]$. For the right shoulder \tilde{G}_i depicted in *Fig. 4(c)*, $h_{\tilde{G}^i}=1$ and $b_{il}(\alpha) = b_{ir}(\alpha) = M$ for for all $\alpha \in [0,1]$.

Because the output of PR must resemble the three kinds of FOUs in a codebook, \tilde{Y}_{PR} can also be an interior, left-shoulder or right-shoulder FOU, as shown in *Fig. 4*. [24], [31], [32]. The α -cut on \bar{Y}_{PR} is $[y_{Ll}(\alpha), y_{Rr}(\alpha)]$ and the α -cut on \underline{Y}_{PR} is $[y_{Lr}(\alpha), y_{Rl}(\alpha)]$, where, as explained in [32], [33], the endpoints of these α -cuts are computed as solutions to the following four optimization problems:

$$\underline{Y}_{PR} = \bigcup_{\alpha \in [0,1]} [y_{Lr}(\alpha | y_{Rl}(\alpha))]. \quad (10)$$

$$\bar{Y}_{PR} = \bigcup_{\alpha \in [0,1]} [y_{Ll}(\alpha | y_{Rr}(\alpha))]. \quad (11)$$

$$y_{Ll}(\alpha) = \frac{\sum_{i=1}^n a_{il}(\alpha) f^i}{\sum_{i=1}^n f^i}, \quad \alpha \in [0,1]. \quad (12)$$

$$y_{Rr}(\alpha) = \frac{\sum_{i=1}^n b_{ir}(\alpha) f^i}{\sum_{i=1}^n f^i}, \quad \alpha \in [0,1]. \quad (13)$$

$$y_{Lr}(\alpha) = \frac{\sum_{i=1}^n a_{ir}(\alpha) f^i}{\sum_{i=1}^n f^i}, \quad \alpha \in [0, h_{\underline{Y}_{PR}}]. \quad (14)$$

$$y_{Rl}(\alpha) = \frac{\sum_{i=1}^n b_{il}(\alpha) f^i}{\sum_{i=1}^n f^i}, \quad \alpha \in [0, h_{\underline{Y}_{PR}}], \quad (15)$$

where

$$h_{\underline{Y}_{PR}} = \min h_{\tilde{G}^i}. \quad (16)$$

Note that *Eqs. (12)-(16)* can easily be computed by EKM algorithms [17], [24], [31–33]. Details of the algorithms for computing \tilde{Y}_{PR} can be found in [26].

Observe from *Eqs. (12)* and *(13)* that \bar{Y}_{PR} , characterized by $[y_{Ll}(\alpha), y_{Rr}(\alpha)]$, is completely determined by \bar{G}^i because it depends only on $a_{il}(\alpha)$ and $b_{ir}(\alpha)$, and from *Eqs. (14)* and *(15)* that \underline{Y}_{PR} , characterized by $[y_{Lr}(\alpha), y_{Rl}(\alpha)]$, is completely determined by \underline{G}^i , because it depends only on $a_{ir}(\alpha)$ and $b_{il}(\alpha)$. Also, observe, from *Eqs. (12)* and *(13)*, that \tilde{Y}_{PR} is always normal; that is, its α -cut can always be computed. It differs from other approximate reasoning methods, such as the Mamdani-inference-based method, whose aggregated fired-rule output sets are abnormal. For the latter, even if only one rule is fired, unless the firing level is one, the output is a clipped or scaled version of the consequent IT2 FS instead of a normal IT2 FS [32]. It may cause problems when the output is mapped to a word in code booking the decoder.

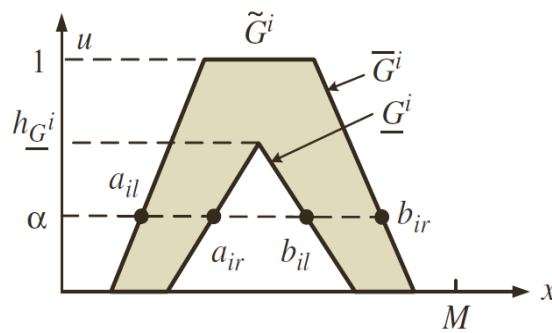

a.

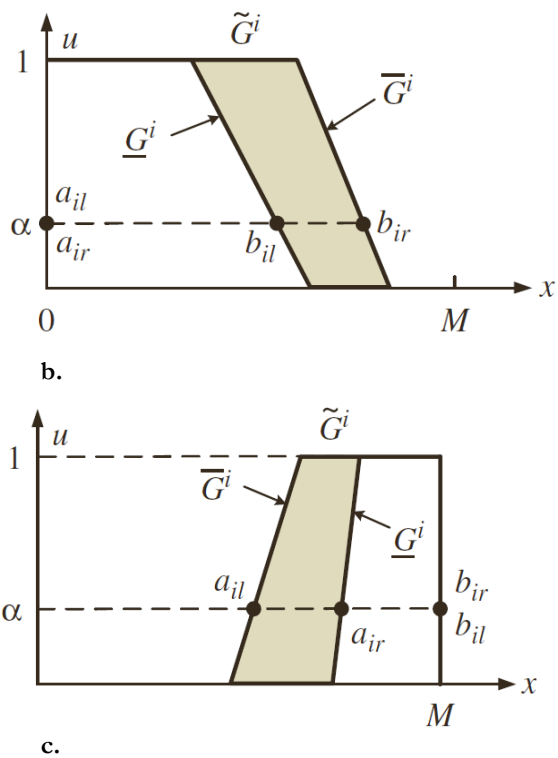
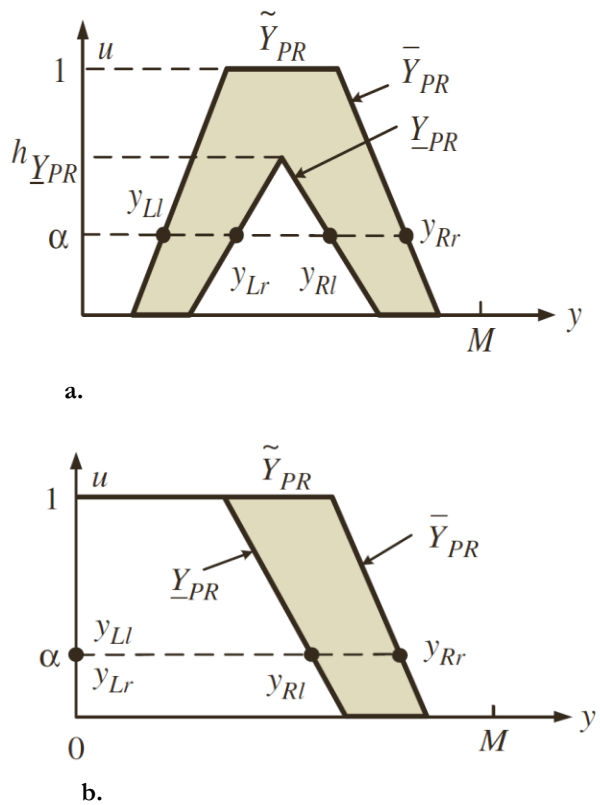
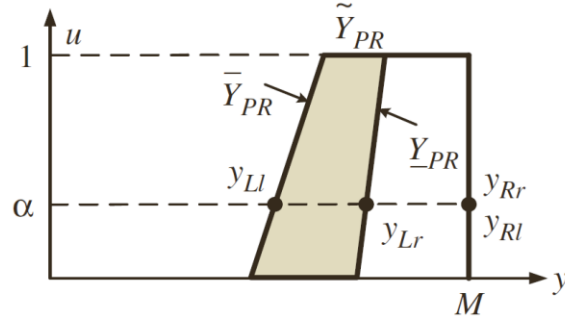

Fig. 4. Typical word FOUs and an α -cut; a. interior FOU, b. left-shoulder FOU, and c. right-shoulder FOU.





c.

Fig. 5. PR FOUs and α -cuts on a. interior, b. left-shoulder, and c. right-shoulder.

In summary, knowing the Firing Levels f^i , $i = 1, \dots, n$, \bar{Y}_{PR} is computed in the following way:

- I. Select m appropriate α -cut for \bar{Y}_{PR} (e.g., divide $[0,1]$ into $m-1$ intervals and set $\alpha_j = (j-1)/(m-1)$, $j = 1, 2, \dots, m$).
- II. Find the α_j α -cut on \bar{G}_i ($i = 1, \dots, n$); denote the endpoints of its interval as $[a_{il}(\alpha), b_{ir}(\alpha)]$, respectively.
- III. Compute $y_{Ll}(\alpha_j)$ in Eq. (4) and $y_{Rr}(\alpha_j)$ in Eq. (5).
- IV. Repeat Steps 2 and 3 for every α_j ($j = 1, \dots, m$).
- V. Connect all left coordinates $(y_{Ll}(\alpha_j), \alpha_j)$ and all right coordinates $(y_{Rr}(\alpha_j), \alpha_j)$ to form the UMF \bar{Y}_{PR} .

Similarly, to compute \underline{Y}_{PR} :

- I. Determine h_{G_i} , $i = 1, \dots, n$, and $h_{\underline{Y}_{PR}}$ in Eq. (8).
- II. Select appropriate p α -cut for \underline{Y}_{PR} (e.g., divide $[0, h_{\underline{Y}_{PR}}]$ into $p-1$ intervals and set $\alpha_j = h_{\underline{Y}_{PR}}(j-1)/(m-1)$, $j = 1, 2, \dots, p$).
- III. Find the α_j α -cut on \underline{G}_i ($i = 1, \dots, n$).
- IV. Compute $y_{Lr}(\alpha_j)$ in Eq. (6) and $y_{Rl}(\alpha_j)$ in Eq. (7).
- V. Repeat Steps 3 and 4 for every α_j ($j = 1, \dots, p$).
- VI. Connect all left coordinates $(y_{Lr}(\alpha_j), \alpha_j)$ and all right coordinates $(y_{Rl}(\alpha_j), \alpha_j)$ to form the LMF \underline{Y}_{PR} .

3.3 | Decoder

The decoder maps the CWW Engine output FOU's into a recommendation. The recommendation from the decoder can have three forms: Word, Rank, and Class. There have been many methods for each of the forms [33]. In this paper, we use Jaccard's similarity to measure the degree of similarity between the results' IT2 FOU's and the codebook to map them into words; for more details on how Jaccard's similarity measure is computed (see [33]).

4 | Proposed Model

As shown in Fig. 6, our proposed model has three stages, each with one or more Per-Cs. In the model, the inputs of the first stage are defined based on the concept of sustainability in economic, environmental, and social dimensions, and the outputs of this stage are the inputs to the second stage; similarly, the outputs of the second stage are the inputs to the third stage, and finally, the outputs of the third stage are the final result of the model. In this model, in the first component of the Per-C method in every stage, namely Encoding,

the EIA method is used. In the second component of the Per-C method, namely the CWW engine, the problem is structured based on an IF-Then Rule-based system, and for solving it, the PR approach is applied in the third component of the Per-C method, namely Decoding, Jaccard's similarity measure is used.

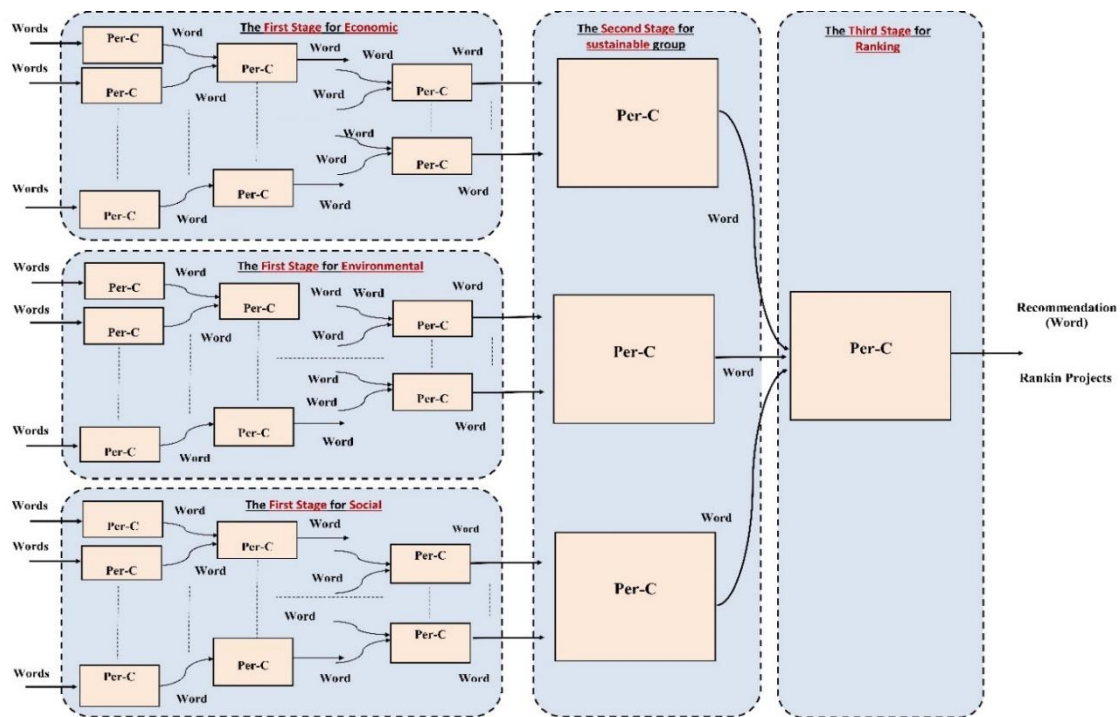

Fig. 6. The general proposed model for selection project.

In the following, steps of the formation and implementation of the proposed model are presented:

Step 1. Define the problem and form a group of experts.

In this step, the problem and its components, including inputs (antecedents), outputs (consequent), and Alternatives, should be defined and formed by a group of experts. In this step, after creating a group of experts, a list of candidate criteria/variables should be prepared for defining inputs and output, then experts are asked to select the desired criteria/variables as inputs (antecedents) and outputs (consequents).

Step 2. Defining a set of words or linguistic terms.

For each criterion/variable, a set of words or linguistic terms should be determined in this step.

Step 3. Construction codebook words (Encoding).

Each expert is asked to collect interval data for each word to generate codebook words. Commonly used scales are 1 through 5, 0 through 5, 0 through 10, and so on for collecting interval data. Then, the collected intervals are used to establish an FOU for each word using the EIA method. You can see details on how data are processed and mapped to IT2 FSs in [31], [32].

Step 4. Establish rules.

Rules are the heart of the CWW engine; in this step, each of the experts in the group establishes a set of rules based on the inputs (antecedents) and outputs (consequents).

Recalling that, a generic if-then rule is represented as

$$R^i: \text{IF } x_1 \text{ is } F_1^i \text{ and } \dots \text{ and } x_p \text{ is } F_p^i, \text{ THEN } y \text{ is } G^i, \quad i = 1, \dots, N, \tag{17}$$

where x_i is called antecedents, and y is called the consequent, and F_1^i, \dots, F_p^i and G^i are words modeled by IT2FSs. These words are defined in Step 2.

Here, it is assumed that each rule is associated with a question of the form. For example, in the two-antecedent rule, if antecedent 1 is (word) and antecedent 2 is (word), then there is (word) of the behavior.

Assuming that each antecedent is described by five FSs, in this rule, there would be 25 questions. Each expert is asked to choose one of the given words for the consequent's FSs. Implementing this step will lead to rule consequent histograms because every expert has to respond differently to a question.

Step 5. Data preprocessing.

Considering the rule's bad responses and outliers, consequent histograms must be eliminated before use. In this step, data in the rule consequent histograms should be preprocessed in three steps: 1) bad data processing, 2) outlier processing, and 3) tolerance limit processing. The details of these steps can be found in [17].

Step 6. Obtaining the aggregated consequent.

Considering that the rule consequent histograms established by the expert responses for each rule, to avoid loss of comments decision makers (DM) and use all of them, an approach for preserving the distributions of the expert responses should be taken. We applied the proposed approach by Wu [26]. The approach is to maintain the distributions of the expert responses for each rule by using a different weighted average to obtain the rule consequences.

Assuming that there are N different combinations of antecedents and each combination has M possible different consequents, there can be as many as MN rules. Denote the m th consequent of the i th combination of the antecedents as \tilde{Y}_m^i ($m = 1, 2, \dots, M, i = 1, 2, \dots, N$), and the number of responses to \tilde{Y}_m^i as w_m^i . For each i , all M \tilde{Y}_m^i can be combined first into a single IT2 FS by a special LWA.

$$\tilde{Y}^i = \frac{\sum_{m=1}^M w_m^i \times \tilde{Y}_m^i}{\sum_{m=1}^M w_m^i}. \quad (18)$$

For example, in a two-antecedent rule

$$R^i: \text{IF } x_1 \text{ is } \tilde{F}_1^i \text{ and } x_2 \text{ is } \tilde{F}_2^i, \text{ THEN } y \text{ is } \tilde{Y}^i, \quad i = 1, \dots, N. \quad (19)$$

\tilde{Y}^i then acts as the new consequent for the i th rule.

Step 7. Computing aggregated \tilde{Y}_{PR} .

The consequent (\tilde{Y}_{PR}) each alternative is computed by using Eq. (20).

$$\tilde{Y}_{PR} = \frac{\sum_{i=1}^N f^i \times \tilde{Y}^i}{\sum_{i=1}^N f^i}, \quad i = 1, \dots, N, \quad (20)$$

where f^i are computed by Eqs. (2) and (3), and \tilde{Y}^i are computed by Eq. (10).

Step 8. Compute the linguistic recommendation.

In this step, \tilde{Y}_{PR} maps into words using Jaccard's similarity measuring.

5 | Case Study

The main goal of this paper is to provide a novel model for sustainable project selection. In this section, the proposed model is applied to a manufacturing company active in the automobile field in Iran. The company after the implementation of the Six Sigma project in the casting department to reduce the scrap rate in the cylinder heads, defined 5 improvement projects as follows:

- I. Install manipulator for discharging parts in shake-out.
- II. Design, making, and utilizing a timer for pouring.
- III. Install Laser Pour in WAGNER for better and more controlled pouring.
- IV. Increase the length of the cooling line for cooling parts in the mold until deformation defects decrease.

V. Exchange the mixer from 2 tons to 3 tons continuously.

Details of the implementation of the proposed model for this case are described in the following:

Step 1. Define the problem and form a group of experts.

For this study, 20 experts were organized as a group of decision-makers. Based on literature reviews and interviews with the group, a list of criteria was prepared, and the participants were asked to determine the desired ones. The results are presented in *Table 2*.

The proposed model has three stages presented in *Fig. 8*. In Stage 1, we considered two Per-Cs in the Economic group and one Per-C for each of the environmental and social groups. This stage has eight inputs (Criteria C₁-C₈) and four outputs: Economic 1, Economic 2, environmental and social. In Stage 2, we considered two Per-Cs for the Sustainable group and two outputs, Economic and environmental-social. Finally, Stage 3 has one output.

Table 2. Inputs/outputs for three stages of the case study.

Dimensions of Sustainability	Criteria/Inputs of Stage 1	Description	Outputs of Stage 1 and Inputs of Stage 2	Outputs of Stage 2 and Inputs of Stage 3
Economic	Time (C ₁)	The time implementation of the project	Economic 1	Economic
	Cost (C ₂)	The cost implementation of the project		
	Reduce waste (C ₃)	The impact of the implementation of the project on reducing quality	Economic 2	
	Quality (C ₄)	The impact of the implementation of the project on increasing quality		
Environmental	Resource consumption (C ₅)	The impact of the implementation of the project on reducing resource consumption	Environmental	Environmental-social
	Environmental pollution (C ₆)	The impact of the implementation of the project on reducing environmental pollution		
Social	Experience and knowledge	Experience and Knowledge in the implementation of the project (C ₇)	Social	
	Learning and growth (C ₈)	The impact on increasing growth and learning of employees		

Step 2. Defining a set of words or linguistic terms.

In the proposed model, all its inputs and outputs are defined using linguistic terms represented by five words: 1) Very Low, 2) Low, 3) Medium, 4) High, and 5) Very High.

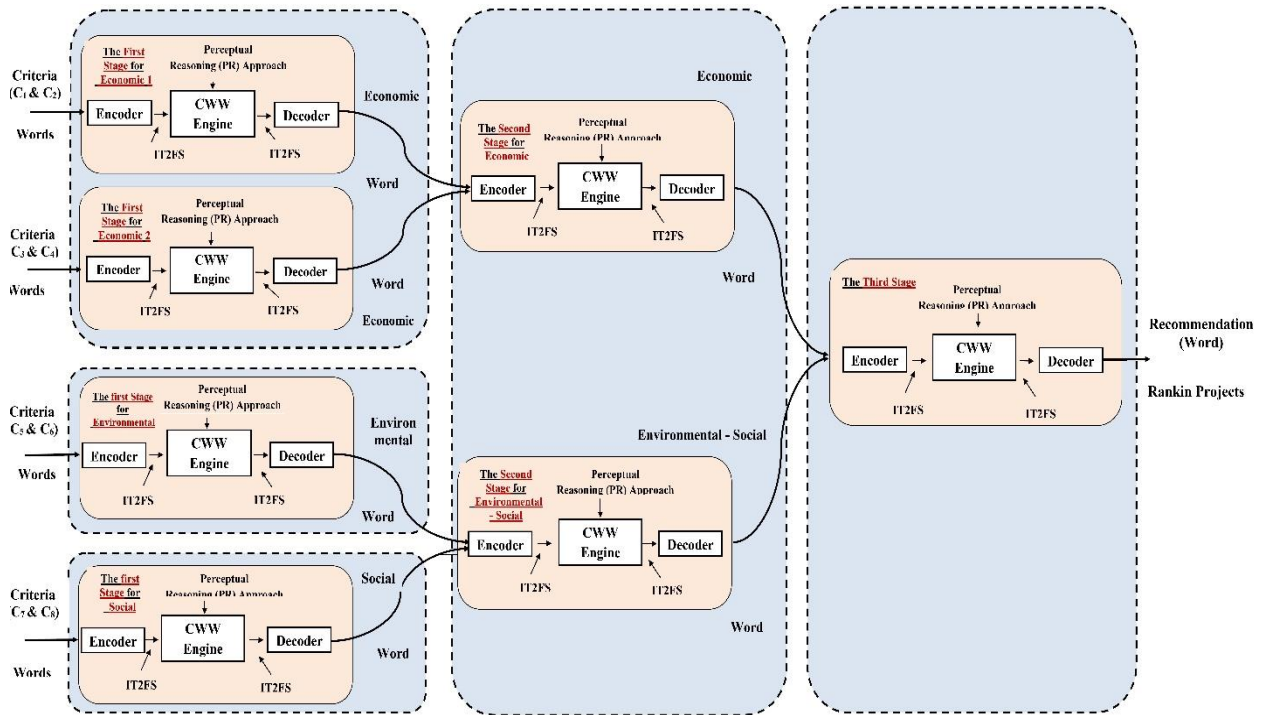

Fig. 8. The ranking project model of the case study.

Step 3. Construction the codebook.

Every stage needs a codebook for inputs (antecedents) and outputs (consequent). We used the EIA method to establish the FOU for each word defined in Step 2 and construct a codebook. In this method, experts are asked to determine interval numbers for assigning these words, after which the interval numbers are mapped into word FOUs. The results of this step are presented in *Table 3*.

Table 3. Used words and FOUs for defining inputs (antecedents) and outputs (consequent) of rules.

Linguistic Terms/Words	FOUs
Very Low (VL)	[(0,0,0.54,1.97;1) (0,0,0.09,1.021;1)]
Low (L)	[(0.58,2,3.25,4.41;0.42) (0.2.29,2.69,2.69,3.02;1)]
Medium (M)	[(1.17,3.5,5.5,7.82;0.39) (4.08,4.65,4.65,5.41;1)]
High (H)	[(4.37,6.5,8,9.41;0.37) (7.29,7.56,7.56,8.20;1)]
Very High (VH)	[(7.36,9.81,10,10;1) (9.37,9.95,10,10;1)]

Step 4. Establish the rules.

In this step, each expert established 25 rules based on the inputs (antecedents) and outputs (consequents), presented in *Table 2* and Fig. 7, to describe all antecedents and consequents in five words. For example, one of the rules in Economic 1 Per-C in the first stage is:

If the cost is Low and time is Medium, then the Priority of the project of Economic 1 dimension is High.

And the other one in Economic 2 Per-C in the first stage is:

IF Reduce Waste is Very Low and Quality is High, then the Priority of the project of Economic 2 dimension is Very High.

After all the experts established the rules in every stage, rule-consequent histograms were formed (*Tables 4-10*). For example, the first row of *Table 4* means that if the value of X1 and X2 are both equal to VL, seven DM considered M for the value of Y, ten DM's considered H for the value of Y and two DM's considered VH for the value of Y.

Table 4. Histogram of two-antecedent rules between criteria $x_1 = \text{cost}$ and $x_2 = \text{time}$, and consequent $y = \text{priority of the project of Economic 1 dimension}$.

No.	x_1/x_2	Y				
		VL	L	M	H	VH
1	VL\VL	0	0	7	10	2
2	VL\L	0	0	8	8	1
3	VL\M	0	0	4	8	1
4	VL\H	0	2	5	10	2
5	VL\VH	1	6	5	4	0
6	L\VL	0	0	6	4	2
7	L\L	0	2	6	9	0
8	L\M	2	1	5	8	3
9	L\H	1	3	5	7	0
10	L\VH	0	2	3	8	3
11	M\VL	0	2	6	10	0
12	M\L	0	1	6	8	1
13	M\M	0	0	7	8	0
14	M\H	0	6	3	5	0
15	M\VH	1	7	2	3	0
16	H\VL	3	8	3	1	0
17	H\L	5	8	2	1	0
18	H\M	6	9	1	0	0
19	H\H	7	9	0	0	0
20	H\VH	9	4	0	0	0
21	VH\VL	8	7	1	0	0
22	VH\L	8	9	2	0	0
23	VH\M	9	8	1	0	0
24	VH\H	11	5	0	0	0
25	VH\VH	16	1	0	0	0

Table 5. Histogram of two-antecedent rules between criteria $x_1 = \text{reduce waste}$ and $x_2 = \text{quality}$, and consequent $y = \text{priority of the project of Economic 2 dimension}$.

No.	x_1/x_2	Y				
		VL	L	M	H	VH
1	VL\VL	20	0	0	0	0
2	VL\L	17	3	0	0	0
3	VL\M	1	5	13	0	0
4	VL\H	0	6	11	2	0
5	VL\VH	0	4	10	6	0
6	L\VL	18	2	0	0	0
7	L\L	0	20	0	0	0
8	L\M	0	8	7	0	0
9	L\H	0	3	10	2	0
10	L\VH	0	0	11	5	0
11	M\VL	2	6	10	0	0
12	M\L	0	3	13	0	0
13	M\M	0	0	20	0	0
14	M\H	0	0	13	7	0
15	M\VH	0	0	11	7	1
16	H\VL	0	6	11	2	0
17	H\L	0	3	10	7	0
18	H\M	0	0	8	10	0

Table 5. Continued.

No.	x_1/x_2	Y				
		VL	VL	VL	VL	VL
19	H\H	0	0	0	20	0
20	H\VH	0	0	0	7	13
21	VH\VL	0	1	11	7	0
22	VH\L	0	0	10	8	0
23	VH\M	0	0	6	10	1
24	VH\H	0	0	0	18	2
25	VH\VH	0	0	0	0	20

Table 6. Histogram of two-antecedent rules between criteria $x_1 =$ resource consumption and $x_2 =$ environmental pollution, and consequent $y =$ priority of the project of environmental dimension.

No.	x_1/x_2	Y				
		VL	L	M	H	VH
1	VL\VL	11	9	0	0	0
2	VL\L	10	7	1	0	0
3	VL\M	4	7	5	0	0
4	VL\H	0	1	4	1	0
5	VL\VH	0	7	3	3	0
6	L\VL	9	8	0	0	0
7	L\L	8	7	1	0	0
8	L\M	3	8	5	0	0
9	L\H	0	3	9	5	0
10	L\VH	0	1	7	8	0
11	M\VL	0	0	8	9	0
12	M\L	0	8	5	1	0
13	M\M	0	1	9	1	0
14	M\H	0	1	12	5	0
15	M\VH	0	0	11	6	0
16	H\VL	0	6	7	1	0
17	H\L	0	3	10	5	0
18	H\M	0	0	11	7	0
19	H\H	0	0	0	15	2
20	H\VH	0	0	3	9	4
21	VH\VL	0	0	12	5	0
22	VH\L	0	0	17	2	0
23	VH\M	0	0	5	14	1
24	VH\H	0	0	0	18	2
25	VH\VH	0	0	0	3	17

Table 7. Histogram of two-antecedent rules between criteria $x_1 =$ experience & knowledge and $x_2 =$ growth & learning, and consequent $y =$ priority the project of social dimension.

No.	x_1/x_2	Y				
		VL	L	M	H	VH
1	VL\VL	11	6	0	0	0
2	VL\L	9	5	0	0	0
3	VL\M	6	7	3	0	0
4	VL\H	0	1	7	1	0
5	VL\VH	0	0	6	1	0
6	L\VL	10	8	0	0	0
7	L\L	9	7	3	0	0
8	L\M	7	4	2	0	0
9	L\H	0	3	6	1	0

Table 7. Continued.

No.	x_1/x_2	Y				
		VL	L	M	H	VH
10	L\VH	0	0	7	2	0
11	M\VL	0	3	6	0	0
12	M\L	0	1	5	0	0
13	M\M	0	2	11	3	0
14	M\H	0	3	10	5	0
15	M\VH	0	0	12	3	0
16	H\VL	0	0	11	5	0
17	H\L	0	0	13	6	0
18	H\M	0	0	8	8	2
19	H\H	0	0	7	11	2
20	H\VH	0	0	2	13	4
21	VH\VL	0	2	8	1	0
22	VH\L	0	1	10	3	0
23	VH\M	0	0	7	11	1
24	VH\H	0	0	4	8	8
25	VH\VH	0	0	0	5	15

Table 8. Histogram of two-antecedent rules between criteria $x_1 =$ priority the project of economic dimension and $x_2 =$ priority the project of Economic 2 dimension, and consequent $y =$ priority the project of economic dimension.

No.	x_1/x_2	Y				
		VL	L	M	H	VH
1	VL\VL	8	6	0	0	0
2	VL\L	3	7	0	0	0
3	VL\M	2	4	5	0	0
4	VL\H	0	3	7	1	0
5	VL\VH	0	1	8	1	0
6	L\VL	10	6	0	0	0
7	L\L	6	14	0	0	0
8	L\M	0	8	9	0	0
9	L\H	0	7	6	0	0
10	L\VH	0	3	12	5	0
11	M\VL	2	12	2	0	0
12	M\L	1	6	5	0	0
13	M\M	0	1	16	1	0
14	M\H	0	0	10	8	0
15	M\VH	0	0	7	8	0
16	H\VL	0	2	7	0	0
17	H\L	0	3	11	1	0
18	H\M	0	0	9	5	0
19	H\H	0	0	0	14	5
20	H\VH	0	0	0	11	8
21	VH\VL	0	0	11	3	0
22	VH\L	0	0	9	6	0
23	VH\M	0	0	7	10	1
24	VH\H	0	0	0	10	8
25	VH\VH	0	0	0	3	17

Table 9. Histogram of two-antecedent rules between criteria x_1 = priority the project of environmental dimension and x_2 = priority the project of social dimension, and consequent y = priority the project of environmental-social dimension.

No.	x_1/x_2	Y				
		VL	L	M	H	VH
1	VL\VL	10	7	0	0	0
2	VL\L	7	5	0	0	0
3	VL\M	3	7	3	0	0
4	VL\H	0	5	8	3	0
5	VL\VH	0	1	5	6	0
6	L\VL	6	9	0	0	0
7	L\L	3	10	0	0	0
8	L\M	1	9	3	0	0
9	L\H	0	5	9	1	0
10	L\VH	0	3	7	2	0
11	M\VL	1	5	8	0	0
12	M\L	2	6	9	0	0
13	M\M	0	1	16	3	0
14	M\H	0	0	11	7	0
15	M\VH	0	0	9	12	0
16	H\VL	0	3	8	0	0
17	H\L	0	1	9	1	0
18	H\M	0	0	9	8	0
19	H\H	0	0	6	13	1
20	H\VH	0	0	3	12	5
21	VH\VL	0	5	7	0	0
22	VH\L	0	2	11	6	0
23	VH\M	0	0	8	7	0
24	VH\H	0	0	5	12	3
25	VH\VH	0	0	0	4	16

Table 10. Histogram of rules between criteria x_1 = priority for the project of economic dimension and x_2 = priority for the project of environmental-social dimension, and consequent y = the final priority of the project.

No.	x_1/x_2	Y				
		VL	L	M	H	VH
1	VL\VL	15	5	0	0	0
2	VL\L	11	9	0	0	0
3	VL\M	5	8	2	0	0
4	VL\H	1	6	7	0	0
5	VL\VH	0	5	10	1	0
6	L\VL	11	8	0	0	0
7	L\L	1	14	0	0	0
8	L\M	0	11	6	0	0
9	L\H	0	5	12	0	0
10	L\VH	0	3	15	0	0
11	M\VL	0	2	13	0	0
12	M\L	0	5	15	0	0
13	M\M	0	0	19	0	0
14	M\H	0	0	15	3	0
15	M\VH	0	0	10	5	1
16	H\VL	0	2	9	1	0
17	H\L	0	6	10	2	0
18	H\M	0	0	7	8	0
19	H\H	0	0	0	17	3
20	H\VH	0	0	0	12	8

Table 10. Continued.

No.	x ₁ /x ₂	Y				
		VL	L	M	H	VH
21	VH\VL	0	3	12	1	0
22	VH\L	0	1	15	2	0
23	VH\M	0	0	3	12	5
24	VH\H	0	0	0	14	6
25	VH\VH	0	0	0	8	12

Table 11. Preprocessed histogram of rules from Table 4, between criteria x₁ = cost and x₂ = time, and consequent y = priority the project of Economic 1 dimension.

No.	x ₁ /x ₂	Y				
		VL	L	M	H	VH
1	VL\VL	0	0	7	10	2
2	VL\L	0	0	8	8	1
3	VL\M	0	0	0	8	0
4	VL\H	0	2	5	10	2
5	VL\VH	1	6	5	4	0
6	L\VL	0	0	6	4	2
7	L\L	0	2	6	9	0
8	L\M	2	1	5	8	3
9	L\H	1	3	5	7	0
10	L\VH	0	2	3	8	3
11	M\VL	0	2	6	10	0
12	M\L	0	1	6	8	1
13	M\M	0	0	7	8	0
14	M\H	0	6	3	5	0
15	M\VH	1	7	2	3	0
16	H\VL	3	8	3	1	0
17	H\L	5	8	2	1	0
18	H\M	6	9	1	0	0
19	H\H	7	9	0	0	0
20	H\VH	9	4	0	0	0
21	VH\VL	8	7	1	0	0
22	VH\L	8	9	2	0	0
23	VH\M	9	8	1	0	0
24	VH\H	11	5	0	0	0
25	VH\VH	16	0	0	0	0

Step 5. Preprocess the data.

The preprocessing process is performed for all histograms (Tables 4-10). Due to the space limitation, only the result of the preprocessing of Table 4 is presented in Table 11.

Steps 6 and 7. Obtain the aggregated consequent and compute the aggregated \tilde{Y}_{PR} .

In this study, 5 projects have been defined for ranking with the specifications presented in Table 12.

The consequent (\tilde{Y}_{PR}), for each alternative is computed using Eqs. (10) and (11). The results are presented in Tables 13-15.

Table 12. Defined projects (alternatives) and their status in each criterion.

No.	Projects	Criteria							
		C ₁	C ₂	C ₃	C ₄	C ₅	C ₆	C ₇	C ₈
1	Install manipulator for discharging parts in shake-out.	M	M	H	M	M	L	L	M
2	Design, making, and utilizing a timer for pouring	VH	VH	H	VH	H	M	M	VH

Table 12. Continued.

No.	Projects	Criteria							
		C ₁	C ₂	C ₃	C ₄	C ₅	C ₆	C ₇	C ₈
3	Install Laser Pour in WAGNER for better and more controlled pouring.	L	L	L	M	VL	M	VH	M
4	Increase the cooling line length for the mold's cooling parts until deformation defects decrease.	M	H	H	H	VH	H	VL	L
5	Exchange the mixer from 2 ton to 3 ton continuous.	VH	VH	VH	VH	VL	M	VL	VH

Step 8. Compute the linguistic recommendation.

In this step, by using Jaccard's similarity measuring, \tilde{Y}_{PR} of each stage map into words (Tables 13-15). The results are presented in Tables 13-15.

For example, in Table 13, in Stage 1: for Economic 1 dimension, the first project has two inputs, C₁ is Medium and C₂ is Medium, based on both the Priority of the project of Economic 1 dimension (\tilde{Y}_{PR}) is High. For the Economic 2 dimension, the first project has two inputs: C₁ is High, and C₂ is Medium. Based on those, the Priority of the project of Economic 2 dimension (\tilde{Y}_{PR}) is High.

For the Environmental dimension, the first project has two inputs: C₁ is Very High, and C₂ is High, on the ground of which is the Priority of the project Environmental dimension (\tilde{Y}_{PR}) is Very High. Finally, for the Social dimension, the first project has two inputs: C₁ is Low, and C₂ is Very High, based on the Priority of the project of the environmental dimension (\tilde{Y}_{PR}) is Medium. In this stage, each of the outputs (\tilde{Y}_{PR}) for the project is an input for the second stage.

Therefore, in the second stage (Table 14), for the Economic dimension, the first project has two inputs, C₁ = the Priority of the project of Economic 1 dimension (\tilde{Y}_{PR}) is High, and C₂ = the Priority of the project of Economic 2 dimension (\tilde{Y}_{PR}) is High, based on which the Priority of the project of Economic dimension (\tilde{Y}_{PR}) is High.

For the environmental-social dimension, the first project has two inputs: C₁ = the Priority of the project of the environmental dimension (\tilde{Y}_{PR}) is Very High, and C₂ = the Priority of the project of Social dimension (\tilde{Y}_{PR}) is Medium, and based on them, the Priority of the project is the environmental-social dimension (\tilde{Y}_{PR}) is High.

In this stage, each of the outputs (\tilde{Y}_{PR}) for the project is input for the third stage.

So in the third stage (Table 15), for the final dimension, the first project has two inputs, C₁ = the Priority of the project of Economic dimension (\tilde{Y}_{PR}) is High, and C₂ = the Priority of the project of environmental-Social dimension (\tilde{Y}_{PR}) is High; consequently, the Priority of the project (\tilde{Y}_{PR}) is High. In Tables 13-15, dashed curves are \tilde{Y}_{PR} and they mapped words in the five-word vocabulary (solid curve) in Table 3. The priority of other projects is defined similarly.

Table 13. Outputs of the first stage of the proposed model.











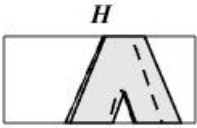
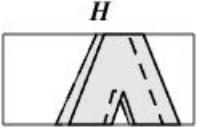
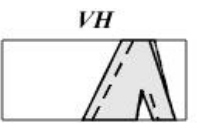
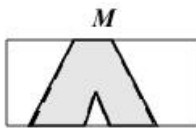

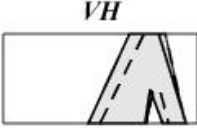
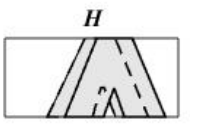
Inputs and Outputs of Stage 1 for Economic 1				Inputs and Outputs of Stage 1 for Economic 2				Inputs and Outputs of Stage 1 for Environmental				Inputs and Outputs of Stage 1 for Social			
No	X ₁ = C ₁	X ₂ = C ₂	Y= Priority of the Project of Economic 1 Dimension (\tilde{Y}_{PR})	No	X ₁ = C ₃	X ₂ = C ₄	Y= Priority of the Project of Economic 2 Dimension (\tilde{Y}_{PR})	No	X ₁ = C ₅	X ₂ = C ₆	Y= Priority of the Project of Environmental Dimension (\tilde{Y}_{PR})	No	X ₁ = C ₇	X ₂ = C ₈	Y= Priority of the Project of Social Dimension (\tilde{Y}_{PR})
1	M	M		1	H	M		1	VH	H		1	L	VH	
2	L	M		2	VH	H		2	H	M		2	M	VH	
3	H	VH		3	VH	L		3	VL	L		3	H	M	
4	L	L		4	L	M		4	VL	M		4	M	L	
5	VH	H		5	H	M		5	VH	M		5	VL	VH	

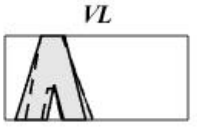
Table 14. Outputs the second stage of the proposed model.

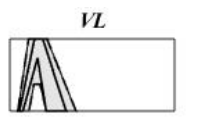
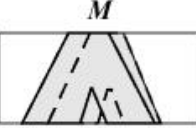
No	X ₁ = Economic 1	X ₂ = Economic 2	Y= Priority of the Project of Economic Dimension (\tilde{Y}_{PR})	X ₁ = Environmental	X ₂ = Social	Y= Priority the Project of Environmental- Social Dimension (\tilde{Y}_{PR})
1						
2						
3						
4						
5						

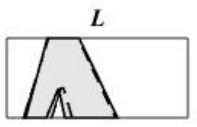
Table 15. Outputs of the third stage of the proposed model and ranking projects.

No	Inputs of Stage 3		Y= Outputs of Stage 3	Rank
	X ₁ = Economic	X ₂ = Environmental-Social		
1				2
2				1
3				4
4				3
5				3

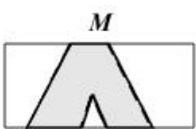
According to the output of the third stage, presented in the third column of Table 15, the priority of projects is $P_2 > P_1 > P_5, P_4 > P_3$.

To test the proposed model's validity, we compared the outputs with the results of the suggested method presented by the company introduced in the case study.

This method scores the projects from 1 to 10 based on two factors. These factors are "the impact on the strategic goals" and "the ability to implement." The final score is obtained by multiplying the two values of factors. The maximum scores are selected as the top priority. The result of the method is shown in *Table 16*.

Table 16. The result of the validity of the model.

Project	The Impact on the Strategic Goals (C ₁)	Ability to Implementation (C ₂)	Final Score	Rank
Install manipulator for discharging parts in shake-out.	7	8	56	2
Design, making, and utilizing a timer for pouring	8	8	64	1
Install Laser Pour in WAGNER for better and more controlled pouring.	5	6	30	5
Increase the length of the cooling line for cooling parts in the mold until the deformation defects.	7	6	42	4
Exchange the mixer from 2 tons to 3 tons continuous.	7	7	49	3

The result of the proposed model is close to the result of the applied method in the company.

6 | Conclusion

This paper presents a novel ranking model based on the Per-C method and the concept of sustainability for selection projects. The main findings are summarized as follows:

- I. Using the Per-C method is a new experience in project selection problems that have not been mentioned in any literature, and its advantages over non-fuzzy methods are used. The benefits of this method over others are that it gets experts' opinions regarding evaluating alternatives and presents outputs as words.
- II. However, the economic criteria are classic processes' most commonly used criteria for project selection problems. Still, sustainability is a modern paradigm that considers project evaluation and selection's economic, social, and environmental effects. Considering the concept of sustainability, the following criteria have been determined as the main criteria in project selection: Cost, Time, and Reduce Waste and Quality as Economic dimensions; resource consumption and environmental pollution as environmental dimension; and growth and learning and knowledge and experience as social dimensions.
- III. According to *Fig. 7*, in addition to using the sustainability concept for determining the criteria, the concept has also been used in designing the model. The proposed model has three stages. The first stage comprises four Per-Cs (two belong to economic and the rest to environmental and social dimensions). In the second phase, the concept of sustainability is fully developed by integrating two economic dimensions with two environmental and social ones. Project rating is addressed in the third phase by using a Per-C. After implementing the proposed model, Projects 2 and 1 were selected as prioritized.
- IV. In decision problems, decision-makers express their evaluations with uncertainties and through linguistic variables. After the process execution, their outputs are presented as pure numbers. In the proposed model, the inputs can be in words and the form of words, rank, or class. In this case study, outputs are presented as words using Jaccard's similarity measure; therefore, the degree of subjectivity is kept.
- V. In new methods such as the FLS, where problems are structured with an IF-Then Rule-based system, the opinions of all decision-makers about all possibilities in rule creation are not considered, whereas the proposed model considers them. According to *Tables 4-10*, all decision-makers opinions are maintained using the PR approach in the Per-C method.

- VI. The obtained results imply decision-makers' satisfaction and applicability of the model when there is numerous numbers of projects for ranking.
- VII. We encourage researchers to use the proposed model in other decision problems and weighting criteria of the model then include the weights in the proposed model as well as other future research using other methods such as FLS plus comparing its results with the model.

We used MATLAB software to solve the problem. All basic codes are available in this website (<http://sipi.usc.edu/~mendel/software>).

Conflict of Interest

The authors declare no conflict of interest.

Data Availability

All data are included in the text.

Funding

This research received no specific grant from funding agencies in the public, commercial, or not-for-profit sectors.

References

- [1] Kucińska-Landwójtowicz, A., Czabak-Górska, I. D., & Rudnik, K. (2021). Methods of improvement project selection: A literature survey. *IFAC-papersonline*, 54(1), 134–139.
- [2] Rezaee, M. J., Yousefi, S., Bagheri, M., & Chakraborty, R. K. (2021). An intelligent strategy map to evaluate improvement projects of auto industry using fuzzy cognitive map and fuzzy slack-based efficiency model. *Computers & industrial engineering*, 151, 106920. <https://www.sciencedirect.com/science/article/pii/S0360835220306057>
- [3] Kucińska-Landwójtowicz, A., Czabak-Górska, I., Rudnik, K., & Lorenc, M. (2020). *Classification of improvement project selection methods* [presentation]. International conference on quality engineering and management (pp. 481–498). <https://publicacoes.riqual.org/icqem-20-481-498/>
- [4] Yang, T., & Hsieh, C. H. (2009). Six-Sigma project selection using national quality award criteria and Delphi fuzzy multiple criteria decision-making method. *Expert systems with applications*, 36(4), 7594–7603.
- [5] Laosirihongthong, T., Samaranayake, P., & McLean, M. W. (2013). Prioritizing of six sigma project selection: a resource-based view and institutional norms perspective. *Innovation for business sustainability & organisational development: Proceedings of the 17th international conference on iso & tqm 17-ICIT* (pp. 1–9). NSW Parliament House and UTS Business School.
- [6] Saghaei, A., & Didekhani, H. (2011). Developing an integrated model for the evaluation and selection of six sigma projects based on ANFIS and fuzzy goal programming. *Expert systems with applications*, 38(1), 721–728.
- [7] Zellner, G., Leist, S., & Johannsen, F. (2010). Selecting critical processes for a six sigma project: Experiences from an automotive bank. *ECIS 2010 proceedings*, 77. <https://aisel.aisnet.org/ecis2010/77/>
- [8] Mansoori, H., Barzoki, A. S., Javadi, M. H. M., & Kianpour, M. (2018). A framework for the selection of organisational empowerment project portfolio based on the human resource practices. *International journal of business innovation and research*, 17(2), 266–291.
- [9] Shaygan, A., & Testik, Ö. M. (2019). A fuzzy AHP-based methodology for project prioritization and selection. *Soft computing*, 23, 1309–1319.
- [10] Padhy, R. K., & Sahu, S. (2011). A real option based six sigma project evaluation and selection model. *International journal of project management*, 29(8), 1091–1102.
- [11] Kalashnikov, V., Benita, F., López-Ramos, F., & Hernández-Luna, A. (2017). Bi-objective project portfolio selection in lean six sigma. *International journal of production economics*, 186, 81–88.

- [12] Sitek, P., & Wikarek, J. (2018). A multi-level approach to ubiquitous modeling and solving constraints in combinatorial optimization problems in production and distribution. *Applied intelligence*, 48, 1344–1367.
- [13] Bermudez Peña, A., Lugo García, J. A., & Piñero Pérez, P. Y. (2015). An adaptive-network-based fuzzy inference system for project evaluation. *Engineering and university*, 19(2), 299–313.
- [14] Khan, M., Deng, S., Rashid, A., Khan, J. A., & Zulfiqar, F. (2017). An integration of kano model, QFD and six sigma to present a new description of DFSS. *European journal of business and management*, 9(6), 1–17.
- [15] Tansakul, N., & Yenradee, P. (2020). Fuzzy improvement-project portfolio selection considering financial performance and customer satisfaction. *International journal of knowledge and systems science (IJKSS)*, 11(2), 41–70.
- [16] Abyaneh, P. M., Nojehdehi, R. R., & Alem, A. (2012). Quality function deployment in engineering, procurement and construction projects. *Journal of basic and applied scientific research*, 2(4), 4167–4173.
- [17] Yazdani, M., Tavakkoli-Moghaddam, R., & Najafi, E. (2021). Project manager selection by using a fuzzy hybrid Delphi-VIKOR approach. *Management research in Iran*, 16(4), 19–44.
- [18] Zhou, T., El-Wahed Khalifa, H. A., Najafi, S. E., & Edalatpanah, S. A. (2022). Minimizing the machine processing time in a flow shop scheduling problem under piecewise quadratic fuzzy numbers. *Discrete dynamics in nature and society*, 2022, 3990534. <https://doi.org/10.1155/2022/3990534>
- [19] Ahmadi, M., Nikseresht, M., Najafi, E., & Morshedi, B. (2020). Landfill site selection using geographic information system and fuzzy-AHP model: A case study of ilam township, Iran. *Journal of environmental health and sustainable development*, 5(3). <https://doi.org/10.18502/jehsd.v5i3.4276>
- [20] Serkani, E. S., Mardi, M., Najafi, E., Jahanian, K., & Herat, A. T. (2013). Using AHP and ANP approaches for selecting improvement projects of Iranian excellence model in healthcare sector. *African journal of business management*, 7(23), 2271–2283.
- [21] Nojehdehi, R. R., Valami, H., & Najafi, S. E. (2011). Evaluating the membership degree of the DMU's related to the fuzzy frontier in DEA with fuzzy input-output levels: A geometrical approach. *Trends in advanced science and engineering. tase*, 4, 7–15.
- [22] Rasi Nojehdehi, R., Bagherzadeh Valami, H., & Najafi, S. E. (2023). Classifications of linking activities based on their inefficiencies in network DEA. *International journal of research in industrial engineering*, 12(2), 165–176.
- [23] Mendel, J. M., & John, R. I. B. (2002). Type-2 fuzzy sets made simple. *IEEE transactions on fuzzy systems*, 10(2), 117–127.
- [24] Wu, D., Mendel, J. M., & John, R. I. (2009). Enhanced type-2 fuzzy sets: interval type-2, general type-2, and their defuzzifications. *IEEE transactions on fuzzy systems*, 17(2), 299–316.
- [25] Mendel, J., & Wu, D. (2010). *Perceptual computing: Aiding people in making subjective judgments*. John Wiley & Sons.
- [26] Wu, D. (2014). A reconstruction decoder for computing with words. *Information sciences*, 255, 1–15.
- [27] Pal, N. R., & Pal, K. (2019). A study of fuzzy rule generation methods. In *Fuzzy models and algorithms for pattern recognition and image processing* (pp. 15–56). Springer. https://doi.org/10.1007/978-3-030-03925-1_2
- [28] Ramírez-Quintana, M. J., & Olivás, F. J. (2020). *Fuzzy logic modeling for the implementation of sustainable business strategies*. Springer International Publishing.
- [29] Tu, J. V. (2019). Fuzzy expert systems in cardiovascular medicine. In *Fuzzy expert systems for disease diagnosis* (pp. 123–145). IGI Global.
- [30] Mendel, J. M., John, R. I., & Liu, F. (2006). Interval type-2 fuzzy logic systems made simple. *IEEE transactions on fuzzy systems*, 14(6), 808–821.
- [31] Mendel, J. M. (2009). Uncertain rule-based fuzzy logic systems. In *Introduction and new directions* (pp. 51–88). Springer.
- [32] Mendel, J. M., & Wu, D. (2007). Perceptual reasoning: a new computing with words engine. *2007 IEEE international conference on granular computing (GRC 2007)* (p. 446). IEEE.
- [33] Mendel, J. M., & Wu, D. (2012). Challenges for perceptual computer applications and how they were overcome. *IEEE computational intelligence magazine*, 7(3), 36–47.